

# Enhancing Cleanroom Design: A Deep Dive into Walk-On Ceilings

Walk-on ceilings are one of the more complex architectural features in controlled environments, requiring careful design and robust construction. GCS, a leader in cleanroom panels, explores the challenges, design considerations, and essential features of world-class walk-on ceilings for cleanrooms.

## Importance of Walk-On Ceilings in Controlled Environments

Walk-on ceilings are integral to many cleanroom designs, offering a safe and reliable platform for maintenance access and housing critical mechanical and electrical systems. This article reviews the key features, benefits, and options that should be considered when selecting and designing these ceilings for cleanroom applications.

Walk-on ceilings must be independently tested and certified, with standards differing by region. The structural design must account for factors such as the supporting framework, load capacities, required spans, and various architectural constraints from the host building. Additionally, performance criteria such as air tightness, moisture resistance, and the ability to withstand harsh cleaning protocols are crucial to ensure the ceiling's longevity and functionality in demanding environments.

GCS's portfolio offers a range of solutions to enhance performance, including hanging systems designed to integrate seamlessly with walk-on ceilings while supporting lighting, ductwork, and other equipment.

## Meeting Regional Compliance Standards

Ceiling load capacities must comply with regional codes. In Europe, EN 13964 is the primary standard, while in the United States, ICC-ES is the most accepted in terms of architectural system performance. Each region applies different safety factors, so it's essential to ensure that comparisons between manufacturers' load tables are based on equivalent testing standards. Any ceiling designated for walk-on access must be rigorously tested in accordance with these codes to ensure safety and compliance.

GCS's SB-05 ceiling system, developed in collaboration with Plasteurop, is designed with both operational and construction-phase challenges in mind. Choosing the correct ceiling system can save valuable time during installation, while improper selection or handling can lead to damage, rendering the ceiling unfit for its intended purpose.

### **Construction-Phase Considerations**

During construction, walk-on ceilings offer both opportunities and risks. A well-designed ceiling system can reduce the need for scaffolding and other mobile equipment, expediting installation and minimizing site congestion. However, risks such as overloading or surface damage caused by dropped tools or scaffold components must be carefully managed.

Surface damage, though sometimes only cosmetic, can compromise the structural integrity of panels, leading to delamination or failure. In response to these challenges, GCS has developed a repair panel system, allowing for localized repairs without the need to replace entire sections of the ceiling. This ensures that only damaged panels are replaced, reducing downtime and costs.

### **Addressing Loading Challenges**

In controlled environments, ceilings must support significant loads, including ductwork, lighting, and electrical systems. These elements not only apply weight to the ceiling but often require cut-outs in the ceiling structure, which can weaken load-bearing capacity. The GCS SBM-07 system is engineered to accommodate high loads while maintaining flush integration of cables and equipment, preserving both aesthetics and structural integrity.

GCS's engineering team utilizes advanced tools and calculations to navigate these challenges, offering tailored solutions such as additional hanging supports or low-profile surface-mounted lighting. Pre-cut ceiling panels can be supplied for lights and filters, ensuring precision and saving critical time on-site during installation.

Early collaboration between the manufacturer's design assistance team, contractors, and other project stakeholders can prevent potential clashes between architectural and engineering requirements, ensuring that ceiling systems are aligned with overall project goals. This includes selecting materials that meet specific environmental requirements, such as chemical resistance, static dissipation, or fire safety.

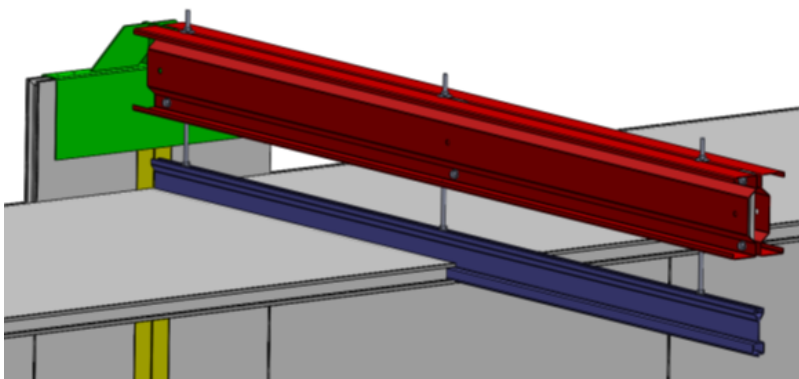

## Innovative Structural Solutions

One common issue with walk-on ceilings is the capacity of older buildings to provide adequate support. Many older structures may not be capable of bearing the loads required for walk-on ceilings. To address this, GCS offers innovative solutions such as the Multibeam system, which allows ceilings to be supported independently of the host building's steelwork or slabs. These beams, capable of spanning up to 35 feet, provide a fully calculated support structure that eliminates the need for reliance on existing building infrastructure.

## Ensuring Airtightness and Moisture Control

In cleanrooms, maintaining airtightness and controlling moisture permeability are critical. However, the flexible nature of walk-on ceilings can make these tasks particularly challenging. Extensive testing is essential to ensure that ceilings perform to the required standards in real-world applications. GCS has experience in meeting the stringent requirements of high-performance cleanrooms, having developed systems that successfully balance flexibility with airtightness and moisture control.

## Sustainability in Cleanroom Design

As sustainability becomes an increasingly important consideration in construction, cleanroom design is no exception. Material selection for walk-on ceilings should prioritize environmental impact, with a focus on reducing embedded carbon. Buyers should look for Environmental Product Declarations (EPDs) when sourcing materials, as these reflect a manufacturer's commitment to transparency and sustainability.

The embedded carbon footprint of ceiling panels can vary significantly depending on the materials used, such as the type of panel core and the grade of steel selected. For example, choosing decarbonized steel can have a meaningful environmental impact, especially when sustainability is a key goal of the project.

## Conclusion

Walk-on ceilings are a vital component of cleanroom architecture, offering both operational and structural benefits. By selecting systems that meet regional compliance standards, are designed to withstand the rigors of both construction and operation and are tailored to the specific needs of the environment, cleanroom providers can ensure long-term success. GCS's expertise in engineering, testing, and material innovation positions them as a leading provider of walk-on ceiling solutions that not only meet the functional requirements of controlled environments but also contribute to the sustainability of modern construction projects.

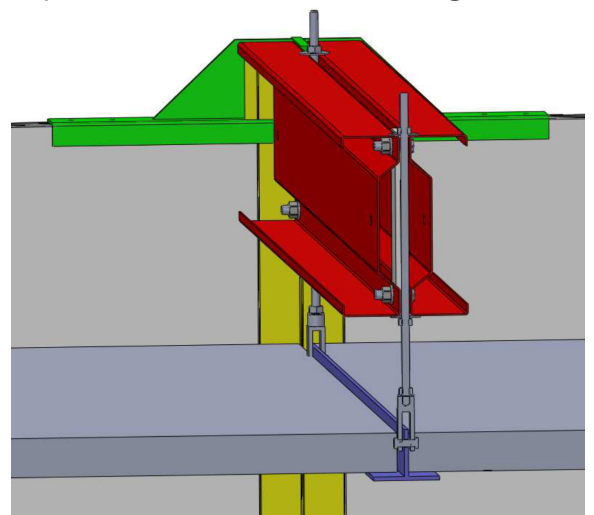

## To start a consultation with GCS:

- **Contact Us:** Reach out via [sales@gcon-cs.com](mailto:sales@gcon-cs.com) or call 979-431-0700.
- **Discuss Your Project:** We'll schedule a detailed discussion to understand your needs and provide a customized solution.

We are here to guide you through every step, from design to installation, ensuring that your cleanroom doors meet the highest standards of quality and performance.

## About GCS:

GCS is the leading manufacturer of cleanroom doors, panels and ceilings for the Life Science, Automotive and Semiconductor industries. GCS began manufacturing cleanroom products in 1978 as Panelco, which was acquired by Summa Equity/G-CON in 2022. Today, GCS has manufacturing locations in the US and France and continues to develop new and innovative products for its comprehensive modular cleanroom portfolio.

## Contact Us:

[sales@gcon-cs.com](mailto:sales@gcon-cs.com)

[www.gconbio.com/clean-solutions](http://www.gconbio.com/clean-solutions)

